

PRIRUBNICA

BROJ PROIZVODA ZA NARUDŽBU

PE - 20

PE - 30

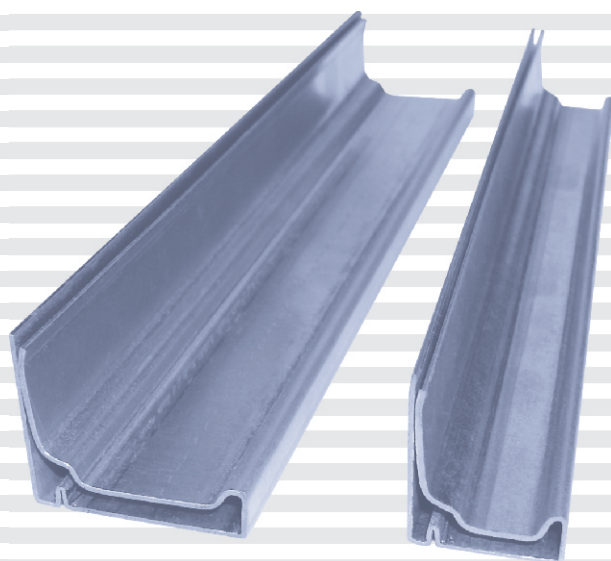

MATERIJAL: pocinčani lim (hladno valjani) za hladno oblikovanje

EN-1995		DIN	
OZNAKA	STANDARD	OZNAKA	STANDARD
DX51D + Z275	10142	St02Z	18162-1

PE-20

DEBLJINA MATERIJALA: 0,7 mm

PAKIRANJE: 1 paket = 500 m, duljine 5000 mm

TEŽINA PAKETA: 244 kg

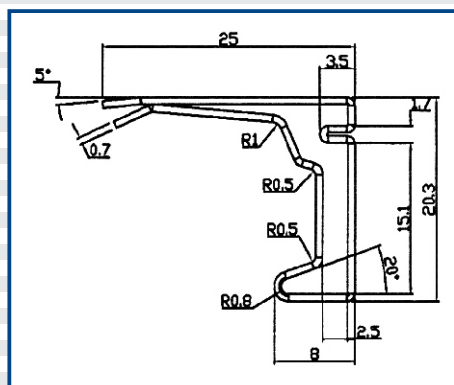

PE-30

DEBLJINA MATERIJALA: 0,8 mm

PAKIRANJE: 1 paket = 500 m, duljine 5000 mm

TEŽINA PAKETA: 345 kg

